



*A Message from*  
**Chris Smith, JN**  
*District Commander*

It is an honor to serve as your commander. I know that with you all by my side I will be able to live up to your expectations. As your commander I promise to listen to all ideas and concerns. I will serve you responsibly and respectfully and create a close bond among our squadrons. Working my way up the ladder to get here I've realized that for the district and the squadrons to function it requires more than just the bridge. It requires our members to volunteer their time and energy. That's why I believe that together we can make this another great year.

This year my goals are not much different than those of our past commanders. This year my goal is to encourage safe boating programs, social activities, member involvement and inter Squadron activities. Together we can encourage students to become members and build up their confidence by encouraging them to further their education while making new friends.

This year's commanders are "All American Anchors." An anchor is the perfect symbol to represent the United States Power Squadron. Anchor is the epitome of our squadrons. We hold each other steady as we brave the storm. Together we are "All American Anchors." We are proud and strong, holding firm to our beliefs and always growing in a place of knowledge, opportunity, and camaraderie. I'll leave with a quote from Frank Bennack, "Nothing is more important to an organization's success than culture and all of us being loyal to the same objective. We should always remember to help fellow members when they need it and care for each other."

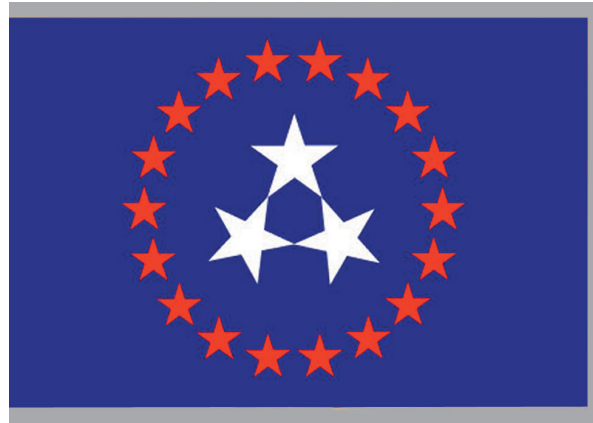

# **THE PAST DISTRICT COMMANDERS OF DISTRICT 3 WISH CHRIS SMITH, JN THE BEST OF LUCK AND A SUCCESSFUL WATCH**

- |                                 |                               |
|---------------------------------|-------------------------------|
| 1982 Daniel Katz, SN            | 2012 Lawrence Postel, SN-ACN  |
| 1985 John Holub, SN-ON          | 2013 Barry Rush, SN           |
| 1989 Guy Anastasio, SN-CN       | 2014 Daniel Flinn, SN         |
| 2002 Richard Frenz, SN          | 2015 Ann Peltier, SN-IN       |
| 2003 Robert Holub, SN-ON        | 2017 Ann Frenz, SN            |
| 2004 Angelo Giovanniello, SN-ON | 2018 Frederick Smith, JN-ACN  |
| 2006 Ron Friedmann, AP          | 2020 Elizabeth Mandara, SN-CN |
| 2008 Peter Tenbrink, SN         | 2021 George Hoffman, SN-ON    |
| 2009 Gardham Comb, SN           | 2022 John Yeamans, SN         |



## J/P/D/C MESSAGE JOHN YEAMANS

Thanks to my Bridge, Aides and Advisors for a very exciting and wonderful 2022-2023 year. My deep appreciation and gratitude to all our Squadron Commanders and their Bridges for supporting the many initiatives that we asked of you and your membership.

What an exciting year; filled with fun and adventure! Sharing my first Squadron COW as your Commander with Captree was special. Each that followed demonstrated to me the uniqueness of our clubs and your commitment to boating.

While our membership did increase ever so slightly over the last year, I am hopeful with the implementation of our "Adopt a Marina Programs" we will help boaters operate more safely and create an incentive for them to join the America's Boating Club.

I've had the privilege of working with so many dedicated committee chairs. Skilled and talented people! No leader accomplishes anything alone. As the saying goes you manage things; you lead people. Again and again you demonstrated your commitment, dedication and willingness to get the job done.

Sometimes people help the Commander and are not looking for recognition and don't wish to be put in the limelight. So it was with P/D/C George Hoffman, our talks on the phone were inspirational. Thank you.

Who can forget our very first "District-wide" ABC- America's Boating Channel Production? Members from several squadrons volunteered their boats & acting talents in creating a boating safety training video titled "Navigating Inlets". It has been approved by the USCG & released for national publication and on the internet.

The fun never seemed to stop! Over 160 of our District 3 members, participated in Rendezvous East, at Greenport. We certainly demonstrated a professional and active image for the public. I for one, will always remember the fellowship and camaraderie of our members.

Now, it's that time for Chris' All American Anchors Watch, one that will be equally innovative and special. I wish him the best and all my support for his year.

In closing, I want to express my deepest gratitude to our members for giving me the opportunity to serve as Commander of this remarkable organization. I leave the District 3 Commander Watch with fond memories and relationships that will continue forever. I also believe I leave the new Bridge well-positioned to meet the opportunities and challenges ahead of them. It has been a privilege to serve you.

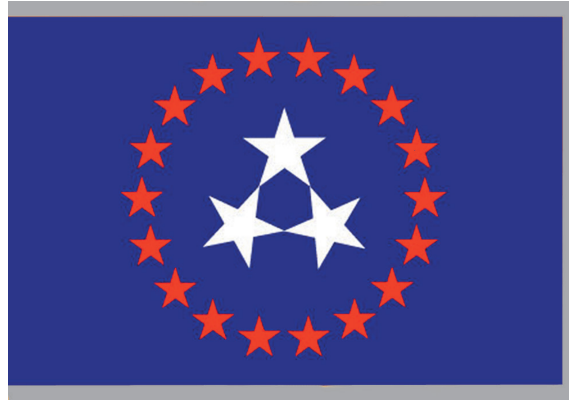

# **THE BEST OF LUCK TO D/CDR CHRIS SMITH, JN AND DISTRICT 3 FOR A SUCCESSFUL WATCH**

D/Lt/C John Pergola, AP

D/Lt/C Doug Durfee, SN

D/Lt/C Robert Natoli, SN-ACN

D/Lt/C Ann Frenz, SN

D/Lt/C Sean Donohoe, SN

D/1st/Lt Joseph Kerner, P

D/1st/Lt Kathleen Wells, AP

D/Fl/Lt James Milton, JN

Chaplain D/Lt Mary Anne McCoy, SN-IN

Advisor Stf/C Angelo Giovanniello, SN-ON

Advisor P/D/C George Hoffman, SN-ON

Advisor Stf/C Robert Holub, SN-ON

Advisor P/D/C Betsy Mandara, SN-CN

Advisor Stf/C Ann Peltier, SN-IN

Advisor P/D/C John Yeamans, SN-ACN

Aide Stf/C Luann Kazanecki, SN-ACN

Aide P/C Ed Figueroa, AP

Aide P/D/C Ann Frenz, SN

Aide D/Lt Jack Stange, AP



# THE BRIDGE



## **CHRIS SMITH, JN -- District Commander and Tracey**

Christopher and Tracey have been very active members since joining Jones Beach Power Squadron in 2009. Upon joining Christopher has worked his way through the ranks to Commander twice. Not stopping there, he also was assistant Treasurer for District and has been an Aide for several past District Commanders. Christopher runs his family's home improvement company and is a finish carpenter by trade.

Besides his obvious love for boating, Chris has many other passions as well. He is an avid hunter and outdoorsman and is very mechanically inclined (He once fixed Sea Tow's boat which was towing his own boat at the time). Chris' boat's name is "Always Something." Those who know Chris understand his boat name perfectly as his credo. Something always breaks and Chris is always fixing it.

Christopher and Tracey have been married for 13 years and live in Amity Harbor with their two dogs Sancho and Paco. The dogs love spending time on the boat with Chris and his wife loves him, so she goes too. One thing the four members of the Smith family all love is their membership and camaraderie with the Jones Beach Power Squadron.



## **JOHN PERGOLA, AP - Executive Officer**

John joined the Great Power Squadron in 2010 because he was interested in gaining as much knowledge as he could about boating. Ascended the squadron bridge from 2016-2021 and served as Commander in 2018 and 2021. He has served on numerous committees over the past seven years and has received the skipper and the pilot award; served as Tent Captain; was a member of the Nominating Committee; was Co-Op Charting Chair for two years and won the Commander's Challenge Award in 2018.

John is a Steam Engineer / Steam Fitter at Brookhaven National Lab. His favorite places to boat on Long Island are Barrett Beach, Davis Park and Garbage Cove. And, when given the choice, he enjoys Atlantique Beach.



## **DOUGLAS DURFEE, SN - Educational Officer and Shirley**

Doug joined USPS/America's Boating Club in 1975. He has 41 merit marks. He was Commander and Squadron Educational Officer of Oyster Bay from 2000-2002. He is currently a Stf/C on the National Navigation Committee.

Doug has been married for 40 years to his wife Shirley. They have one daughter, Noelle, who is a Physician's Assistant at Mercy Hospital.

Doug looks forward to encouraging/promoting/ providing incentives for the educational program of USPS/America's Boating Club



# **THE COMMANDERS OF DISTRICT 3 WISH CHRIS SMITH, JN THE BEST OF LUCK AND A SUCCESSFUL WATCH**

Bayside	Seth Cirker, SN-CN
Captree	Thomas Zimmer, AP
Great South Bay	James Milton, JN
Hempstead Bay	Ann Wellandar, AP
Jones Beach	Robert Dearing, SN-ACN
Neptune	Stuart Timm, AP
Oyster Bay	Kevin Kuo, JN
Patchogue Bay	Loretta Yeamans, SN-ACN
Peconic Bay	Diane Sherman, P
Port Washington	Robert Kovach, SN
Sewanhaka	Fred Deppert, AP
Smithtown	Tom Rondi, AP
South Shore	Debra Daly, S



## THE BRIDGE (cont'd.)



**ROBERT A. NATOLI, SN - Administrative Officer SN-ACN**  
Bob has been an active member of Jones Beach since 1999. He served as Chaplain, Chairman of Local Boards, Radio Technical, Secretary, Merit Mark Chairman, AO, XO and Commander from 2021-2023. Bob worked for NBC for 43 years. The first 12 years he worked in the radio division and worked his way up to Chief Engineer. He then moved over to television in the Operations and Engineering Department. He won an Emmy as a Video Engineer for the 2012 Olympic Games in London. He retired in 2017 after his wife passed away. After retirement, he worked his way up to achieve the grade of SN-AN, and won the Commanders Challenge in 2022.



**ANN FRENZ, SN - Secretary and Richard**  
Ann joined Patchogue Bay Power Squadron in 1989 and has 33 merit marks. She was elected Commander of Patchogue Bay for 2004-2005 and placed first in the Commander's Challenge. In 2017 she became District Commander after becoming Asst. Secretary, Secretary, AO and XO. She was a PRC of the Ships Store, Chair of the Social Activities Committee and works with Richard at the National level. Ann retired as a teacher and administrator in 1998 from the Bayport-Blue Point School District. She taught at all levels and chaired the committee of Special Education. Ann has been married to RC Richard for 54 years and have two children, Kimberly and Matthew and 6 grandchildren. Both Ann and Richard enjoy boating on their 38 ft power boat, Karma II and can often be found in Greenport or other East end areas. They love traveling on land and sea.

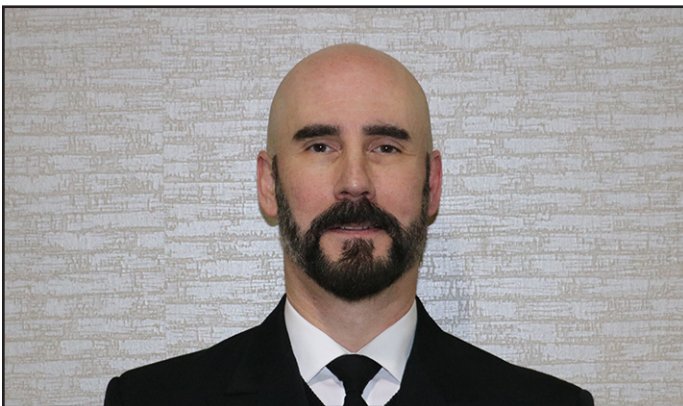

**SEAN DONOHOE, SN - Treasurer**  
Sean has been an active member of the Bayside Power Squadron since 1998. He served as Squadron Commander from 2004-2006 and currently serves as Squadron Treasurer and for the past year, he has served as the District 3 Assistant Treasurer. After his term as Squadron Commander, he served as District Chairman of the Leadership Development Committee and has been an aide and flag lieutenant to many District Commanders. Sean is between boats right now. He used to have a 30-foot Boston Whaler Sport Fisherman spending a lot of time fishing and travelling on the Long Island Sound. Sean was a sergeant in the New York City Police Department and retired in 2012 after 20 years of service. He is actively looking for a boat so he does not have to go to Rendezvous East by car anymore. He is single and lives in Queens.



**JAMES MILTON, JN - Flag Lieutenant**  
James joined Great South Bay Power Squadron in 2007 and has held positions of Asst SEO, EO, XO, and Cdr. He is a very active young man who has been dedicated and successful in his endeavors. He is the founder and team leader of the Squadron Emergency Response Team whose mission is to provide on-water emergency support on the Great South Bay and has been Captain and Team leader since its inception. James is the Chairman of the National Member Benefits Committee and was recently awarded the Dominic Segrete Award for going above and beyond for District 3. James has also received the United States Power Squadron Lifesaving award for his actions on July 27, 2017 when he saved the life of a child and his father who were both caught by the current when swimming behind their boat and were unable to make it back. James grew up boating on the south shore of Long Island and enjoys off-shore fishing for tuna and other large fish in his 25' Steiger Craft named "Moonlight Shadow". His occupation is Head of Information Technology at Flexim Americas Corporation and by all accounts is quite good at what he does. When he is at home he enjoys his two cats Phillip and Toby.



## District 3 Rendezvous Beach Blast 2023

WATCH HILL MARINA

FIRE ISLAND NATIONAL SEA SHORE, LI, NY

28 - 29 July 2023

**THURSDAY - 27 JULY** Early arrival, Tent Set-Up & Prep by Volunteers

**FRIDAY - 28 JULY** Tent, TABLE, CHAIR Set-Up & Prep by Volunteers

**SATURDAY - 29 JULY**

8:00 AM Trail Walk - meet at trail entrance on East Dock at Bay

9:00 AM Bagel Breakfast

11:00 AM Flag Ceremony, At the Ferry Dock Flagpole

Members - Red-White-Blue attire

12:15

**Meeting with DXO John Pergola Incoming 2024 Squadron Commanders & D3 Bridge**

1:00 - 4:30 PM RENDEZVOUS ON THE BEACH BLAST

4:00 PM RAFFLE DRAWING

4:30 PM

Clean Up - Thanks to all Volunteers!! Relax! Enjoy the Marina & Ocean and Bay Beaches

**Saturday Night** Evening Socializing under the tent

**Sunday** Boat departures - *Safe Trip Home!*

Boat Reservations through DOCKWA.com online reservation system

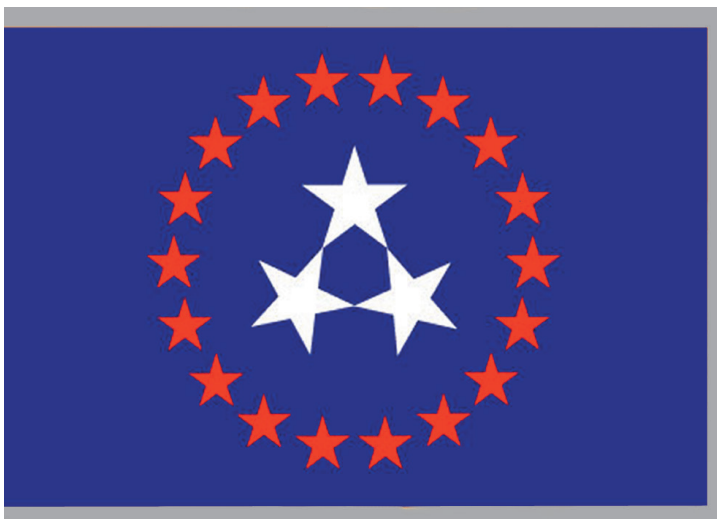

## DISTRICT 3 FLAG

The District 3 Flag was approved by the National Flag and Etiquette Committee and adopted in 2000. The significance of the flag design is as follows: The three white stars signifying District 3 are enclosed in a circle of 18 red stars symbolizing the 18 squadrons of District 3 at that time. The blue background symbolizes the waters surrounding Long Island. The flag is embellished with a platinum border signifying District 3 has attained its seventy-fifth anniversary.

This new District 3 flag was designed by Stf/C Angelo V. Giovanniello, SN-ON.



**THE BRIDGE** (cont'd.)



**Joseph P. Kerner, JN**  
Asst Educational Officer



**Kathleen Wells, AP**  
Asst Treasurer

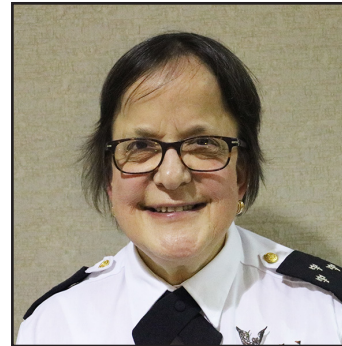

**Mary Anne McCoy, SN-IN**  
Chaplain



**Angelo Giovanniello, SN-ON**  
ADVISOR



**Robert Holub, SN-ON**  
ADVISOR



**Ann Peltier, SN-IN**  
ADVISOR



**Betsy Mandara, SN-CN**  
ADVISOR



**George Hoffman, SN-ON**  
ADVISOR



**John Yeamans, SN-ACN**  
ADVISOR



**Ann Frenz, SN**  
AIDE



**Edward Figueror, AP**  
AIDE



**Luann Kazanecki, SN-ACN**  
AIDE



**Jack Stange, AP**  
AIDE



# ALL-AMERICAN ANCHORS

District 3 is unique in the long-standing tradition that the District Commander chooses a significant name and symbol to characterize the identity for their year in office and thereafter. The tradition started in 1965 with D/C Frank Haslach, N. His commanders formed a close friendship and wanted to continue the camaraderie after their terms of office ended.

Each district has their own unique traditions that they like to follow when beginning a new year with a new bridge. The District 3 commander has the privilege to come up with a name for their members and create a symbol to go along with the name. I have proudly created the name, “All-American Anchors”

Anyone who knows me knows how “All-American” I truly am and that part is somewhat self-explanatory. However, I do want to explain a little more about the “All-American” part and how it describes us, District 3. There are also a lot of reasons why I thought “Anchors” was the perfect name to describe our members and our entity as a district.

Like our great nation, District 3 is comprised of people who aspire to achieve greatness. All our members, like most Americans, can come from humble beginnings to achieve greatness. It is a place of opportunity, camaraderie, growth, and personal fulfillment.

America’s Boating Club is always looking for new and exciting ways to inspire boaters, young and old, to become members. Online courses and creative boating safety courses are the key to our success. With community outreach and social networking District 3 will continue to encourage those who wish to acquire knowledge and growth through safer boating.

I was extremely shy and nervous when I joined District 3, but I was allowed the opportunity for personal growth. But the most challenging times brings us the greatest rewards. The members of the squadron were my anchors and held me steady as I braved the storm.

We are all anchors to each other; holding each other steady during life’s storms. I view District 3 as an anchor. We are grounded, we are strong, and we support each other. We are the “All-American Anchors”: Proud, strong, holding firm to our beliefs, and always growing in a place of knowledge and opportunity.

---

*Journal Staff Chair: Stf/C Angelo V. Giovannello, SN-ON, 631-661-5318*

*Advertising Information: D/Lt Heidi Dearing, S 516-316-0767 Content: P/D/Lt Lucy Jackson, SN 631-289-2328*

*Photographers: P/D/C George Hoffman, SN-ON • P/D/C Betsy Mandara, SN-CN*

# SQUADRON



# COMMANDERS



## BAYSIDE

SETH CIRKER, SN-CN and Sarah  
38 Richards Rd, Port Washington, NY 11050 • 516-883-8848  
[scirker@gmail.com](mailto:scirker@gmail.com)

Meetings: 3rd Monday of the month, St Anastasia's Parish Center, Douglaston



## HEMPSTEAD BAY

ANNA M. WELLANDER, AP  
23 Pine Tree Drive, Farmingdale, NY 11738 • 516-293-7773  
[hbpsinfo@yahoo.com](mailto:hbpsinfo@yahoo.com)

Meetings: Last Thursday of the month, American Legion, Valley Stream



## CAPTREE

THOMAS ZIMMER, AP and Pam  
10 Jeffrey Lane, North Babylon, NY 11703 • 631-242-1065  
[topaz.two@verizon.net](mailto:topaz.two@verizon.net)

Meetings: 3rd Wednesday of the month, Moose Lodge, Lindenhurst



## JONES BEACH

ROBERT DEARING, SN-ACN and Heidi  
160 N Kings Ave N Massapequa, NY 11758 • 516-316-0390  
[ourdream160@yahoo.com](mailto:ourdream160@yahoo.com)

Meetings: 1st Thursday of the month, American Legion Hall, Seaford



## GREAT SOUTH BAY

JAMES M. MILTON, JN  
105 Jefferson St. East Islip, NY 11730 • 631-681-7650  
[jmilton040@gmail.com](mailto:jmilton040@gmail.com)

Meetings: Ancient Order of Hibernians' at 65 Champlin Ave, East Islip  
Check BoatGSB.org for day of meetings



## MORICHES BAY

JOHN TAYLOR, JN and Janet  
30 Wedgewood Lane, Brookhaven, NY 11719 • 631-286-0599  
[farmer61sn1@yahoo.com](mailto:farmer61sn1@yahoo.com)

Meetings: 4th Tuesday of the month, JC's Restaurant at Mike's Place Too, Mastic



## ACTIVITIES OF DISTRICT 3

### Rendezvous Event – 28 - 30 July 2023

District 3 is planning something different this year for our Rendezvous. The location will be Watch Hill Marina at Fire Island and the theme will be “Beach Blast Picnic.” So, come on down and have a great time at the beach! Come by boat or ferry. Let’s have a fun filled, sun filled day at the beach. The D3 Anchors will provide some befitting and enjoyable activities under the tent for all to enjoy with their family and friends. The agendas will be distributed to the commanders of each squadron when available. Saturday 29 July will be the main event under the tent. This will consist of tons of food, activities, music, and dancing. You don’t want to miss this day! The tent, however, will be up and available on Friday 28 July for members to spend time together. For any information you can always refer to the D3 website [weboatsafe.org](http://weboatsafe.org) or contact the Chairmen below:

**Co-Chairmen:** D/Lt Ross Herzog - 631-406-7514 and D/Lt/C Robert Natoli, SN-ACN - 516-445-2699

### Fall Educational Conference-Melville Marriott 04 November. 2023

The morning of the Educational Conference is devoted to seminars on USPS education courses. There is also a juried display of teaching aids submitted by the various squadrons. After lunch the D/3 Conference convenes to act on district business and present education and teaching aids awards.

**Chairman:** D/Lt Dick Jost, SN 631-374-8453 and D/Lt Luke Closs, SN 516-799-0032

### Spring Conference and Change of Watch - 15-16 March 2024

The Spring Conference weekend will be held at the Melville Marriott. It begins with the D/C s' Cocktail Party Friday evening. On Saturday morning, there is a keynote speaker followed by workshops for the various committees. After lunch, the conference reconvenes with District awards and concludes with the District Change of Watch. Squadrons open their hospitality rooms in the afternoon and a dinner dance closes the festivities Saturday evening.

**Chair:** P/R/C Angelo V. Giovanniello, SN 631-661-5318

### Educational Hotline - 1-800-341-USPS (8777)

The educational hotline gives callers information on boating courses in their area. The recorded message gives the dates, locations and contact persons for the boating courses offered by squadrons of D/3. Messages are updated continuously.

**Chairman:** D/Lt Linda C. Bradley, SN - 631- 243-5240

### Boat Shows

District 3 secures space and sets up a booth at local boat shows to dispense information about boating classes and USPS. We are represented at boat shows held at TOBAY, Javits Center, Nassau Coliseum and other local venues. The booth is staffed by representatives of the D/3 squadrons.

**Chairmen:** D/Lt Gil Allen, SN-ON - 516-551-9883

### Council Meetings

#### 12 May, 20 October 2023 and 01 March 2024

The meetings are held at the Melville Marriott. One may come for attitude adjustment hour at 1830 and dinner at 1900, The meetings begin promptly at 2000. All members of District 3 are welcome.

### Memorial Service - Sunday 14 April 2024

All American Commanders expected at 1500 and the Service begins at 1530 at the Cross of Christ Church, in Babylon, NY. On Sunday afternoon members, families and friends pause to remember those members of our district who have departed from us during the year. Refreshments follow the church service.

**Chairman:** J/P/D/C Christopher Smith, JN - 516-721-6100

### Website

The District maintains a website, [weboatsafe.org](http://weboatsafe.org) and [usps.org/localusps/D3](http://usps.org/localusps/D3) to keep members up-to-date on all the happenings in District. Looking for a specific course? The website lists member courses offered by the squadrons as well as public boating courses. You will also find the district calendar which lists the various social activities happening in squadrons around Long Island. All activities in any squadrons are open to any USPS member.

**Webmaster:** P/D/C Ann Peltier, SN-IN, 631-447-1051



### NEPTUNE

STUART TIMM, AP

27 Grant Street, East Northport, NY 11731 • 631-754-6724

[mitshu.boficus@gmail.com](mailto:mitshu.boficus@gmail.com)

Meetings: 3rd Thursday in Sept., Nov., Mar., & June, Northport Yacht Club



### PATCHOGUE BAY

LORETTA YEAMANS, SN-CN and John

5 Fairfax Drive, Farmingville NY 11738 • 631-736-0541

[loretta526@gmail.com](mailto:loretta526@gmail.com)

Meetings: 2nd Friday of the month, Suffolk Boat Club, Patchogue



### OLD FIELD POINT

RONALD GUZEWICH, SN and Terry

10 Andrea Drive, Setauket, NY 11733 • 631-689-3982

[rguzewich@msn.com](mailto:rguzewich@msn.com)

Meetings: 1st Monday of the month, Mount Sinai Yacht Club



### PECONIC BAY

DIANE SHERMAN, P and Glen

149 D Riverside Drive, Riverhead, NY 11901 • 631-877-0510

[diane@happycove.com](mailto:diane@happycove.com)

Meetings: 3rd Thursday of the month at various locations



### OYSTER BAY

KEVIN P. KUO, AP and Celeste

20 Westminster Road, Syosset, NY • 516-433-2973

[kevinkuo97@gmail.com](mailto:kevinkuo97@gmail.com)

Meetings: 2nd Monday of the month, Sagamore Yacht Club, Oyster Bay



### PORT WASHINGTON

ROBERT KOVACH, SN and Nancy

86-15 Broadway, Apt 15E, Elmhurst, NY 11373 • 718-271-2055

[challenge767@yahoo.com](mailto:challenge767@yahoo.com)

Meetings: 3rd Monday of the month, N. Shore Yacht Club, Port Washington



## What is a Vessel Safety Check?

A vessel safety check is a courtesy examination of a boat to verify the presence and operable condition of certain safety equipment required by state and federal regulations. The Vessel Examiner is a trained specialist and is a member of America's Boating Club or the US Coast Guard Auxiliary. They will also make certain recommendations and discuss safety related issues that will make boat owners safer boaters.

The inspection is really quick and easy. Many trailerable boats can be inspected in ten minutes. All boaters will receive a copy of the evaluation form at the end of the inspection. Boats that meet the safety requirements will receive a current Vessel Safety Check decal to be displayed on board.

## District 3 Squadrons and Vessel Safety Check Contacts

SQUADRON	CONTACT	
1 BAYSIDE	EUGENE MOLteni, SN-ON	718-224-2124
2 CAPTREE	CHARLES VIRGA, AP-IN	631-335-4169
3 GREAT SOUTH BAY	JAMES M. MILTON, JN	631-681-7650
4 HEMPSTEAD BAY	NOEL GUZMAN, AP	718-507-0910
5 JONES BEACH	ROBERT HOLUB SN-ON	516-795-4211
6 MORICHES BAY	RICHARD LANNI, P	631-399-2766
7 NEPTUNE	DON LaGRECO, AP	631-271-8561
8 OLD FIELD POINT	JOHN PETERSON, S	631-585-7432
9 OYSTER BAY	DENNIS PUCCIO, S	631-628-2109
10 PATCHOGUE BAY	ROBERT GROOS, SN-CN	631-879-8686
11 PECONIC BAY	ROBERT SANANGELO, SN	631-655-7520
12 PORT WASHINGTON		
13 SEWANHAKA	ROBERT STEEL, AP	516-872-8167
14 SMITHTOWN BAY	ALLAN HILTUNEN, SN	631-265-6561
15 SOUTH SHORE	SETH GOLDSTEIN, JN	516-431-0157

Trailered Boats can be brought to selected marine centers or arrange for a future VSC appointment at their boat launches, marinas or yacht clubs with a Vessel Examiner in your area from the list shown on the left. Vessel Safety Checks are not a boarding or a law enforcement issue. No citations will be given if boats do not meet safety requirements. Your boat will pass inspection once the requirements are met. Listed on left are the Vessel Safety Check Chairmen.

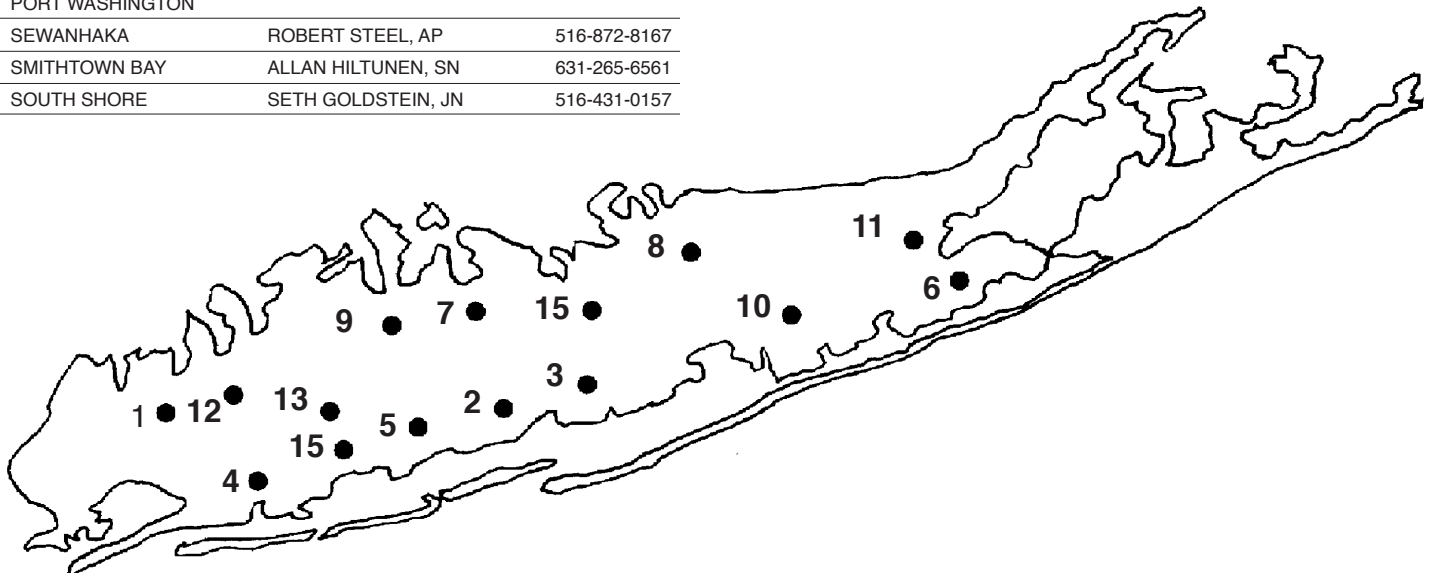



**SEWANHAKA**

CYRIL FABIJANIC, P

12 Brown Street, Sea Cliff, NY 11579 • 516-661-3774

[captcyril12@verizon.net](mailto:captcyril12@verizon.net)

Meetings: 3rd Thursday of the month, Guy Lombardo Marina. Freeport,



**SMITHTOWN BAY**

THOMAS RONDI, AP and Ann Marie

103 Harvard Avenue. Smithtown, NY 11787 • 631-360-9850

[tomrondi@gmail.com](mailto:tomrondi@gmail.com)

Meetings: 2nd Wednesday of the month, Stony Brook Yacht Club



**SOUTH SHORE**

DEBRA DALY, S and Larry

52-52 State Route 145, Cobleskill, NY 12043 • 631-860-4198

[sunshinedaly13@aol.com](mailto:sunshinedaly13@aol.com)

Meetings: 2nd Thursday of the month, Baldwin Park, Seaford

*District 3 is unique in the long-standing tradition that the District Commander chooses a significant name and symbol to characterize the identity for their year in office and thereafter. The tradition started in 1965 with D/C Frank Haslach, N. His commanders formed a close friendship and wanted to continue the camaraderie after their terms of office ended.*

Haslach's Has Beens  
Pallas Guards  
Angnello's Angels  
Earl's Pearls  
Tom's Cats  
Raskin's Rascals  
Donald's Ducks  
Wally's Wheels  
Kess' Crew  
Burgio's Buoy  
The Marksmen  
Bob's Beacons  
Shed's Sharpies  
Howard's Skippers  
Bill's Bosun's

Braun's Buccaneers  
Danny's Dolphins  
The Whales  
Davis' Clippers  
Holub's Seahorses  
Pollio's Pilots  
Al's Anchors  
Leo's Lights  
Guy's Gulls  
Joe's Mariners  
Dave's Dories  
Karl's Cruisers  
Harry's Helmsmen  
Jack's Stars  
Montague's Marlins

Friedland's Fisherman  
Ron's Rays  
Terry's Pirates  
Bradley's Barracudas  
Camelot Commanders  
The Leprechauns  
Frenz's Frigates  
Bob's BraveHearts  
Angelo's Angels  
Taylor's Tankers  
Friedmann's Foghorns  
Bob's Buccaneers  
Pete's Pelicans  
Gar's Lifesavers  
Sanfilippo's Penguins

Eric's Eagles  
Larry's Lanterns  
Barry's Bosuns  
Dan's Navigators  
Peltier's Pearls  
Neil's Dolphins  
The Seafaring Frenz  
Fred's Defenders  
Tom's Terrapins  
Betsy's D/3 Sea Stars  
George's Lines  
Yeaman's Mariners



# DISTRICT 3 GENEALOGY

By 1938 the United States Power Squadrons was an organization of 5,000 members with 33 squadrons. That year the Governing Board approved the establishment of 7 divisions and they appointed a Rear Commander to administer each division. Later the designation division was changed to District and in 1947 the officer in charge was changed to the elected position of District Commander. The New York squadron had provided pre-charter instruction to the Brooklyn (1918) and South Shore (1928) squadrons. Brooklyn helped to establish Bay-

side (1936) which, in turn, spun-off Neptune (1938). District 3 was officially established on 13 December 1938 to include the Brooklyn, South Shore, Bayside, and Neptune squadrons. The district grew for thirty-five years reaching a peak in 1970 of over 5,000 members in 21 squadrons. With less interest in boating, membership declined drastically during the late 70s and early 80s, but the tide has turned and District 3 has again begun to grow. In 2019 District 3 now has 15 active squadrons.

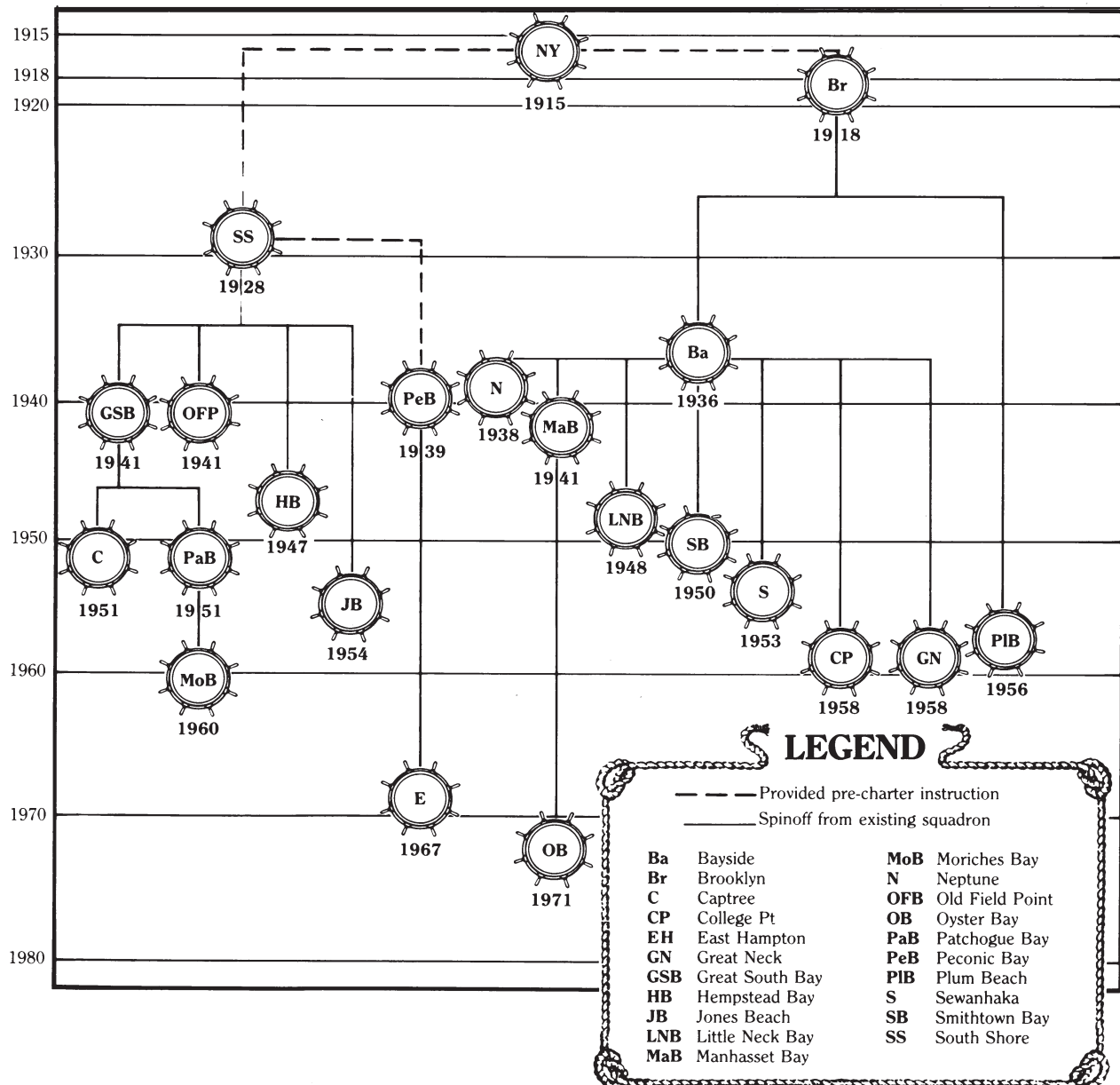





# DISTRICT 3 AWARDS AND TROPHIES

## Cruise and Rendezvous Trophy

The present Cruise and Rendezvous Trophy, a large handsome trophy cup mounted on a two-tiered walnut pedestal, is a perpetual District 3 award presented annually at the Fall Conference for boating participation at the District Rendezvous. The winner of the trophy is determined by a formula that takes into account the distance traveled to the Rendezvous location, and the number of squadron boats in attendance relative to the total membership of a squadron.

The idea of a Cruise and Rendezvous Trophy was jointly conceived by the members of Patchogue Bay and Peconic Bay squadrons. The original trophy, donated by Peconic Bay Power Squadron in 1967, was to be an annual award with the stipulation that any squadron that won the award three times would be entitled to keep it. Patchogue Bay succeeded in winning the award in 1968, 1969, and 1970. Thus they took permanent possession of the original trophy. To continue the award the following year Patchogue Bay donated a new trophy for presentation with the same contest rules applying. It did not seem likely

that a squadron could dominate the competition again. However, Great South Bay Power Squadron achieved this winning the trophy in 1971, 1972, and 1973.

The following year, Great South Bay Power Squadron reinstated the award. This time, however, the "three consecutive wins" rule, entitling a squadron to keep the trophy, was dropped to assure that this would be a perpetual award. Great South Bay squadron purchased the present trophy and deeded it to the District in 1974. Great South Bay has gone on to win the award 29 of the 35 years, including seventeen years in a row. In 2014 Jones Beach won the award and in 2013, 2015 & 2016, 2017, and 2019 the trophy was won by Patchogue Bay. Recipient 2022: Captree



### PRINCE HENRY AWARD

The seated likeness of Prince Henry the Navigator of Portugal was given to a number of USPS districts by the government of Portugal for promoting education in the art of navigation.

In D/3 this award is presented at the Spring Conference to the squadron who had the highest percentage of members advance in grade. The recipient is determined by a point system that takes advanced grades relative to the total membership of the squadron. Recipient: 2022 Bayside



### HAEDRICH MEMORIAL TROPHY

The Brooklyn Power Squadron established the Haedrich Memorial Bell Trophy in remembrance of Harold W. Haedrich who was a past commander of Brooklyn Squadron and one of the original commanders of District 3. The ringing of the Haedrich bell traditionally opens and closes our district conferences.

The trophy is awarded at the Spring Conference based on a complex formula that takes into account advanced grades and elective courses completed and membership retention. Recipient: 2022 Patchogue Bay



